

# Model No. A14-L3506

## 3/8" AIR DRILL

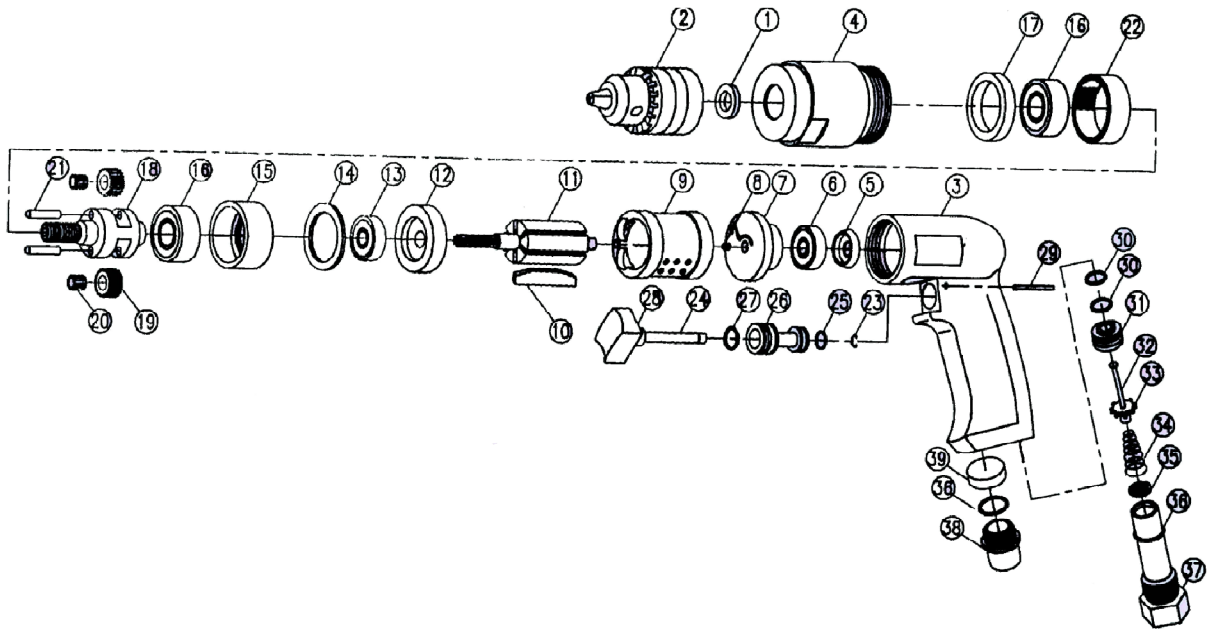

Part No.	Description	Q'ty	Part No.	Description	Q'ty
1	Chuck Spacer	1	21	Needle Roller	2
2	Drill Chuck	1	22	Ring Gear	1
3	Body	1	23	E-Ring	1
4	Sleeve	1	24	Valve Spindle	1
5	Rear Bearing Cap	1	25	O-Ring	1
6	Ball Bearing	1	26	Valve Body	1
7	Raer End Plate	1	27	O-Ring	1
8	Spring Pin	2	28	Trigger	1
9	Cylinder	1	29	Spring Pin	1
10	Rotor Blade	6	30	O-Ring	2
11	Rotor	1	31	Bushing	1
12	Front End Plate	1	32	Valve Pin	1
13	Ball Bearing	1	33	Valve	1
14	Rubber Gasket	1	34	Spring	1
15	Bearing Cap	1	35	Filter	1
16	Ball Bearing(6001)	2	36	O-Ring	2
17	Steel Washer	1	37	Air Inlet	1
18	Rear Complete	1	38	P/M Silencer	1
19	Idler Gear	2	39	Spongy Silencer	1
20	Needle Bearing	2			